



## 1. Types, construction and characteristics

Spherical roller bearings consist of an outer ring having a continuous spherical raceway within which operates two rows of barrel-shaped rollers which are in turn guided by an inner ring with two raceways separated by a center rib. (Refer to **Diagram 1**) This bearing has self-aligning properties, and therefore is suited for use where misalignment between the inner and outer rings occurs from housing installation error or shaft flexure.

Spherical roller bearings have a large capacity for radial loads, axial loads in either direction, and complex loads. They are also suited for applications where vibration and shock loads are encountered. When operating under axial loads, however, it is desirable to maintain conditions so that  $F_a/F_r \leq 2e$  in order to prevent sliding movement along the row of rollers not receiving the axial load. (For the value of  $e$ , refer to dimension tables.)

As shown in **Table 1**, in addition to standard type there are various other types of spherical roller bearings. Among these, **Type E** has a particularly high load capacity.

In addition to bearings with cylindrical bore, those with tapered bore are also available. Bearings with tapered bore are specified by attaching the suffix "K" to the end of the bearing's basic number. The standard taper ratio is 1:12 for bearings with a "K" suffix, but for bearings in series 240 and 241 the suffix "K30" indicates the taper ratio for a bearing is 1:30. Most tapered bore bearings incorporate the use of adapters and withdrawal sleeves for shaft mounting.

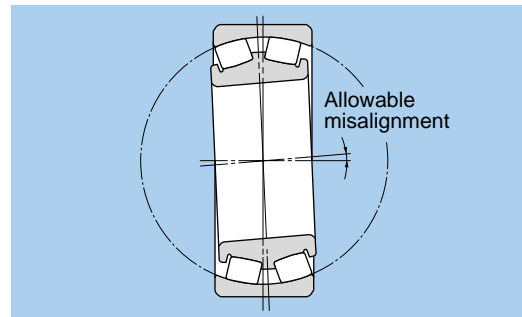
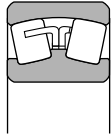
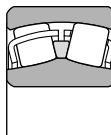

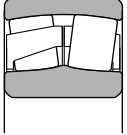

Diagram 1.

Table 1 Types of spherical roller bearings

Type	Standard type (B type)	C type	213 type	E type
Construction				
Bearing series	Does not include C type	Series 222, 223, and 213 with bore dia. of 50 mm or less; series 24024 to 24038.	Series 213 with bore dia. of 55 mm or more	Series 22211 to 22218
Rollers	Asymmetrical	Symmetrical	Asymmetrical	Symmetrical
Roller guide method	Unified inner ring center rib	By guide ring between the 2 rows of rollers	By guide ring between rows of rollers on outer ring raceway	High precision cage (no guide ring, center rib)
cage type	Pressed cage; machined cage	Pressed cage	Machined cage	Molded resin cage

## 2. Standard cage types

Standard cage types for spherical roller bearings are shown in **Table 2**. In general, pressed cages are standard for small sized bearings, and machined cages are standard for large sized bearings.

E type bearings use as their standard cage type a cage molded from a newly developed glass fiber reinforced **polyamide 46 resin which has excellent heat resistance qualities (allowable operating temperatures up to 150°C)**, strength, as well as unsurpassed oil resistance.

A standard cage may however not be able to be used for high-speed specifications, in high temperature atmospheres, or under excessive vibration/impact conditions. For more information concerning such conditions, please contact NTN Engineering.

**Table 2 Standard cage types**

Bearing series	Molded resin cage	Pressed cage	Machined cage
239	-	-	23932 ~ 239/1400
230	-	23022B ~ 23048B	23052B ~ 230/1120B
240	-	24024C ~ 24038C	24024B ~ 240/1120B
231	-	23120B ~ 23136B	23138B ~ 231/900B
241	-	-	24122B ~ 241/710B
222	22211E ~ 22218E	22208C ~ 22210C 22211B ~ 22236B	22238B ~ 22264B
232	-	-	23218B ~ 232/750B
213	-	21308C ~ 21310C	21311 ~ 21322
223	-	22308C ~ 22310C 22311B ~ 22328B	22330B ~ 22360B

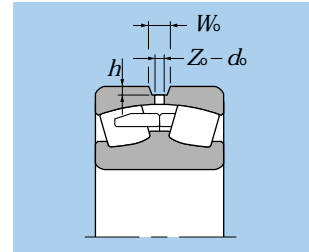

**Table 3 Oil inlet and oil groove dimensions**

Units mm

Nominal bearing width		Oil groove width $W_o$	Oil inlet diameter $d_o$	Oil groove depth $h$	
over	including			Width series 1, 2, 3	Width series 4
-	30	6	3	1.2	1.0
30	45	7	4	1.5	1.1
45	60	9	5	1.5	1.3
60	80	11	6	2.0	1.5
80	100	14	8	2.5	2.0
100	120	16	10	3.0	2.5
120	160	20	12	3.5	3.0
160	200	27	16	5.0	3.5
200	315	33	20	6.0	5.0
315	-	42	25	7.0	6.5

**Table 4 Oil inlet number**

Nominal bearing outer diameter	mm	Oil inlet number $Z_o$
over up to	including	
-	320	4
320	1 010	8
1 010	-	12

If a pin is necessary to prevent outer ring rotation, contact NTN Engineering.

## 3. Oil inlets and oil groove dimensions

Spherical roller bearings with an outer diameter of 320mm or more are provided with an oil inlet and oil groove on the outer ring for the purpose of supplying lubricant to the bearing's moving parts. When necessary, oil inlets and oil grooves can also be provided on bearings with outer diameters less than 320 mm. In such cases, please add the supplementary suffix code "D1" to the end of the bearing number, and contact NTN Engineering. (Refer to page A-29)

**Table 3** lists dimensions for oil inlets and oil grooves. **Table 4** contains information about the number of oil inlets.

## 4. Allowable misalignment

Spherical roller bearings possess the same self-aligning properties as other self-aligning bearings. The allowable misalignment angle will vary according to dimension series and load conditions, but the following misalignment angles are generally standard:

Normal load (loads equivalent to 0.09 C):	.....0.009rad (0.5°)
Light load:	.....0.035rad (2°)

## 5. Adapters and withdrawal sleeves

Adapters are used for installation of bearings with tapered bore on cylindrical shafts. Withdrawal sleeves are also used to install and disassemble bearings with tapered bore onto and off of cylindrical shafts. In disassembling the bearing from the shaft, the nut is pressed down against the edge of the inner ring utilizing the bolt provided on the withdrawal sleeve, and then the sleeve is drawn away from the bearing's inner diameter surface. (Precision of adapter and withdrawal sleeve are stipulated JIS B 1552 and JIS B 1556).

For bearings with a bore diameter of 200 mm or more, high pressure oil (hydraulic) type adapters and withdrawal sleeves have been standardized to make installation and disassembly easier. As shown in **Diagram 2** construction is designed to reduce friction by injecting high pressure oil between the surfaces of the adapter sleeve and bearing inner bore by means of a pressure fitting.

If the oil supply inlet is attached in the nut side of the adapter, the supplementary suffix "HF" should be added to the bearing number; if the oil supply inlet is attached on the opposite side, the suffix "HB" should be added to the bearing number. For adapter sleeves, the supplementary suffix "H" is added to the bearing's number in both cases.

The hydraulic sleeve nut is equipped with holes for bolts used for mounting and dismounting and holes for hydraulic piping. The suffix SP or SPB is added to the bearing number of the nut.

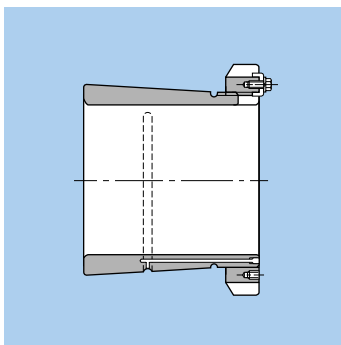

Diagram 2.

## 6. LH series

In recent years, conditions under which spherical roller bearings are used have become increasingly severe. In particular, longer life is now demanded for use in high temperature environments.

Taking the global environment into account, NTN Engineering has developed a type of steel (STJ2) that offers longer life in a wide range of temperatures, from room temperature all the way up to 250°C. The steel is standardly used in NTN Engineering's **LH series of spherical roller bearings**.

Features are as follows (in comparison with SUJ2):

**(1) Longer life in wide range of temperatures.**

- 3.5 times longer life at room temperature.
- 30 times longer life at high temperature (250°C).

**(2) Resists surface damage.**

- 7 times stronger resistance to peeling
- 1.4 times stronger resistance to smearing
- 2.5 times stronger resistance to wear

**(3) Dimensions stability at high temperatures.**

- Almost no dimensional variation when maintained at 250°C.

**(4) Enhanced cracking fatigue strength.**

- 2 times longer cracking fatigue life under high temperatures or tight fitting stress.
- 2 times better operating cracking fatigue strength.

**(5) Simplified service part stock management.**

- Applications ranging from room temperature to 250°C can be handles with a single type of standard bearing.

Items with LH preceding the basic number in the dimensions table are LH series and are gradually being switched.

Bearing numbers without LH can be manufactured according to size. For information, please contact NTN Engineering.

